

## Tabella di conversione pollici/millimetri

Ø in pollici	Decimali in pollici	Equivalente in millimetri	Ø in pollici	Decimali in pollici	Equivalente in millimetri
$\frac{1}{32}$	$\frac{1}{64}$	0.15625	$\frac{33}{64}$		5.15625
$\frac{1}{16}$	$\frac{3}{64}$	0.46875	$\frac{35}{64}$		5.46875
$\frac{3}{32}$	$\frac{5}{64}$	0.78125	$\frac{37}{64}$		5.78125
$\frac{1}{8}$	$\frac{7}{64}$	1.09375	$\frac{39}{64}$		6.09375
$\frac{5}{32}$	$\frac{9}{64}$	1.40625	$\frac{41}{64}$		6.40625
$\frac{3}{16}$	$\frac{11}{64}$	1.71875	$\frac{43}{64}$		6.71875
$\frac{7}{32}$	$\frac{13}{64}$	2.03125	$\frac{45}{64}$		7.03125
$\frac{1}{4}$	$\frac{15}{64}$	2.34375	$\frac{47}{64}$		7.34375
$\frac{9}{32}$	$\frac{17}{64}$	2.65625	$\frac{49}{64}$		7.65625
$\frac{5}{16}$	$\frac{19}{64}$	2.96875	$\frac{51}{64}$		7.96875
$\frac{11}{32}$	$\frac{21}{64}$	3.28125	$\frac{53}{64}$		8.28125
$\frac{3}{8}$	$\frac{23}{64}$	3.59375	$\frac{55}{64}$		8.59375
$\frac{13}{32}$	$\frac{25}{64}$	3.90625	$\frac{57}{64}$		8.90625
$\frac{7}{16}$	$\frac{27}{64}$	4.21875	$\frac{59}{64}$		9.21875
$\frac{15}{32}$	$\frac{29}{64}$	4.53125	$\frac{61}{64}$		9.53125
$\frac{1}{2}$	$\frac{31}{64}$	4.84375	$\frac{63}{64}$		9.84375
	$\frac{1}{2}$	5	<b>1</b>		1

## Quadri per utensili sec. DIN 10

dimensioni - tolleranze quote in mm



diametro gambo d <sub>2</sub>		Quadro k valore nominale	Quadro esterno		L
da	a		max.	min.	
2,47	2,83	2,1	2,100	2,010	5
2,83	3,20	2,4	2,400	2,310	5
3,20	3,60	2,7	2,700	2,610	6
3,60	4,01	3,0	3,000	2,910	6
4,01	4,53	3,4	3,400	3,280	6
4,53	5,08	3,8	3,800	3,680	7
5,08	5,79	4,3	4,300	4,180	7
5,79	6,53	4,9	4,900	4,780	8
6,53	7,33	5,5	5,500	5,380	8
7,33	8,27	6,2	6,200	6,050	9
8,27	9,46	7	7,000	6,850	10
9,46	10,67	8	8,000	7,850	11
10,67	12,00	9	9,000	8,850	12
12,00	13,33	10	10,000	9,850	13
13,33	14,67	11	11,000	10,820	14
14,67	16,00	12	12,000	11,820	15
16,00	17,33	13	13,000	12,820	16
17,33	19,33	14,5	14,500	14,320	17
19,33	21,33	16	16,000	15,820	19
21,33	24,00	18	18,000	17,820	21
24,00	26,67	20	20,000	19,790	23
26,67	29,33	22	22,000	21,790	25
29,33	32,00	24	24,000	23,790	27
32,00	34,67	26	26,000	25,790	29
34,67	38,67	29	29,000	28,790	32
38,67	42,67	32	32,000	31,750	35
42,67	46,67	35	35,000	34,750	38
46,67	52,06	39	39,000	38,750	42
52,06	58,67	44	44,000	43,750	47
58,67	65,33	49	49,000	48,750	52
65,33	73,33	55	55,000	54,700	58
73,33	81,33	61	61,000	60,700	64
81,33	90,66	68	68,000	67,700	71
90,66	101,33	76	76,000	75,500	79

## CODOLO CON FORO FILETTATO

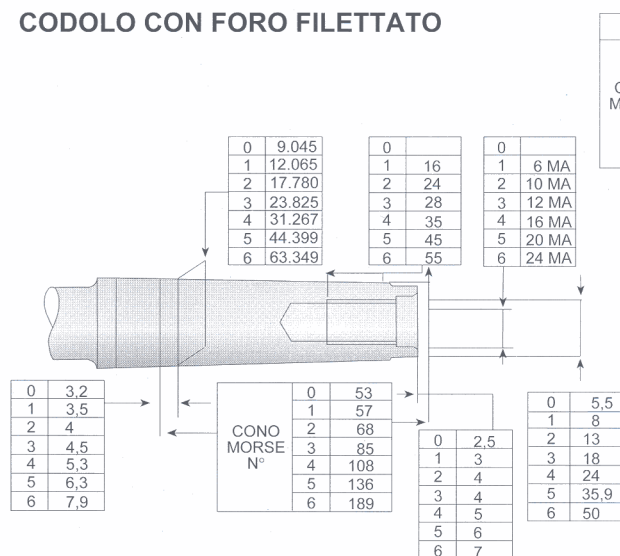

## CODOLO CON LINGUETTA

